

ELBOW

90° 長徑彎頭

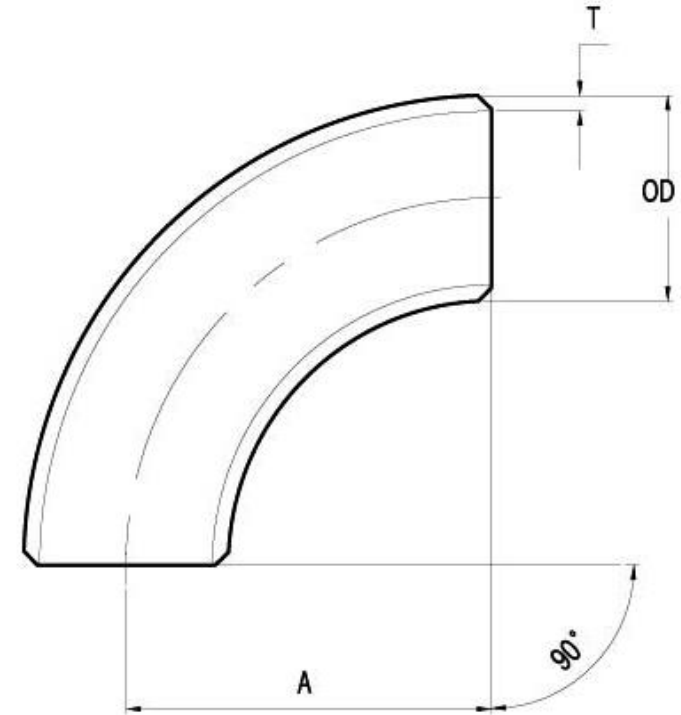

DIMENSIONS		(unit: inch / mm)				
Nominal Pipe Size	Outside Dia. (OD)	Wall Thickness(T)				Center to END A
		Sch. 5S	Sch. 10S	Sch. 40S	Sch. 80S	
1/2	0.840	0.065	0.083	0.109	0.147	1.500
	21.340	1.650	2.110	2.770	3.730	38.100
3/4	1.050	0.065	0.083	0.113	0.154	1.120
	26.670	1.650	2.110	2.870	3.910	28.450
1	1.315	0.065	0.109	0.133	0.179	1.500
	33.400	1.650	2.770	3.380	4.550	38.100
1.1/4	1.660	0.065	0.109	0.140	0.191	1.880
	42.160	1.650	2.770	3.560	4.850	47.750
1.1/2	1.900	0.065	0.109	0.145	0.200	2.250
	48.260	1.650	2.770	3.680	5.080	57.150

WEIGHTS		(unit: kg)			
Nominal Pipe Size	Sch. 5S	Sch. 10S	Sch. 40S	Sch. 80S	
1/2	0.049	0.060	0.076	0.097	
3/4	0.062	0.057	0.076	0.098	
1	0.078	0.156	0.16	0.193	
1.1/4	0.125	0.201	0.253	0.334	
1.1/2	0.17	0.279	0.363	0.485	

2	2.375	0.065	0.109	0.154	0.218	3.000
	60.320	1.650	2.770	3.910	5.540	76.200
2.1/2	2.875	0.083	0.120	0.203	0.276	3.750
	73.020	2.110	3.050	5.160	7.010	95.250
3	3.500	0.083	0.120	0.216	0.300	4.500
	88.900	2.110	3.050	5.490	7.620	114.300
3.1/2	4.000	0.083	0.120	0.226	0.318	5.250
	101.600	2.110	3.050	5.740	8.080	133.350
4	4.500	0.083	0.120	0.237	0.337	6.000
	114.300	2.110	3.050	6.020	8.560	152.400
5	5.563	0.109	0.134	0.258	0.375	7.500
	141.300	2.770	3.400	6.550	9.530	190.500
6	6.625	0.109	0.134	0.280	0.432	9.000
	168.270	2.770	3.400	7.110	10.970	228.600
8	8.625	0.109	0.148	0.322	0.500	12.000
	219.080	2.770	3.760	8.180	12.700	304.080
10	10.750	0.134	0.165	0.365	0.500	15.000
	273.050	3.400	4.190	9.270	12.700	381.000
12	12.750	0.156	0.180	0.375	0.500	18.000
	323.850	3.960	4.570	9.530	12.700	457.200
14	14.000	0.188	0.312	0.375	0.500	21.000
	355.600	4.780	7.920	9.530	12.700	533.400
16	16.000	0.188	0.312	0.375	0.500	24.000
	406.400	4.780	7.920	9.530	12.700	609.600
18	18.000	0.188	0.312	0.375	0.500	27.000
	457.200	4.780	7.920	9.530	12.700	685.800
20	20.000	0.218	0.375	0.375	0.050	30.000
	508.000	5.540	9.530	9.530	12.700	762.000
22	22.000	0.218	0.375	0.375	0.500	33.000
	558.800	5.540	9.530	9.530	12.700	838.200
24	24.000	0.250	0.375	0.375	0.500	36.000
	609.600	6.350	9.530	9.530	12.700	914.400
26	26.000	0.312	0.500	0.375	0.500	39.000
	660.400	7.920	12.700	9.530	12.700	990.600
28	28.000	0.312	0.500	0.375	0.500	42.000
	711.200	7.920	12.700	9.530	12.700	1066.800

2	0.286	0.470	0.651	0.894
2.1/2	0.576	0.786	1.29	1.7
3	0.81	1.160	2.02	2.74
3.1/2	1.08	1.550	2.84	3.9
4	1.39	2.000	3.84	5.34
5	2.83	3.460	6.51	9.25
6	4.03	4.960	10.1	15.3
8	7.06	9.550	20.3	30.9
10	13.2	16.600	36	48.8
12	22.3	25.800	53	69.9
14	34.6	56.7	68	89.9
16	45.2	74.3	89.2	118
18	57.3	94.2	113	150
20	82	140	140	185
22	99.4	170	170	225
24	136	202	202	268
26	198	315	238	315
28	230	366	276	366

30	30.000	0.312	0.500	0.375	0.500	45.000
	762.000	7.920	12.700	9.530	12.700	1143.000
32	32.000	0.312	0.500	0.375	0.500	48.000
	812.800	7.920	12.700	9.530	12.700	1219.200
34	34.000	0.312	0.500	0.375	0.500	51.000
	863.600	7.920	12.700	9.530	12.700	1295.400
36	36.000	0.312	0.500	0.375	0.500	54.000
	914.400	7.920	12.700	9.530	12.700	1371.600
38	38.000	0.312		0.375	0.500	57.000
	965.200	7.920		9.530	12.700	1447.800
40	40.000	0.312		0.375	0.500	60.000
	1016.000	7.920		9.530	12.700	1524.000
42	42.000	0.312		0.375	0.500	63.000
	1066.800	7.920		9.530	12.700	1600.200
44	44.000	0.312		0.375	0.500	66.000
	1117.600	7.920		9.530	12.700	1676.400
46	46.000	0.312		0.375	0.500	69.000
	1168.400	7.920		9.530	12.700	1752.600
48	48.000	0.312		0.375	0.500	72.000
	1219.200	7.920		9.530	12.700	1828.800

30	264	421	317	421
32	301	479	361	479
34	339	542	408	542
36	381	608	457	608
38	425		510	678
40	471		565	751
42	520		624	829
44	571		685	910
46	624		749	995
48	679		815	1084



大甲永和機械工業股份有限公司

Add : 台中市大甲區幼獅路69號

Tel : 886-4-2681-5496

Tachia Yung Ho Machine Industry Co., Ltd

No.69, Youshi Rd., Dajia Dist., Taichung City 437, Taiwan

Fax : 886-4-2681-5456 Web : www.yhmc.com.tw