



DAJA







大甲永和

DAJA-UHP-5-2.1

UHP CGA/DISS Fittings Series



Contents

Description	Page	
General Introduction	01	
Materials of Construction	01	
Features	01	
Gas Connection Assignment Table	02	
Technical Specification	03	
Product Codes	04	
Nipple(10)	05	
Nipple Product Table	06	
 <p>■ Nipple(10) Butt-Weld type</p>	 <p>■ Nipple(10) NPT type</p>	 <p>■ Nipple(10) Face Seal type</p>
Nut(20)	08	
Nut Product Table	08	
 <p>■ Nut(20)</p>		
Gasket(30)	08	
Gasket Product Table	08	
 <p>■ Gasket(30)</p>		
Outlet Plug(50)	08	
Outlet Plug Product Table	08	
 <p>■ Outlet Plug(50)</p>		

General Introduction

The design and proof-test confirms to UHP CGA V-1-2005, 12th edition.

Materials of Construction

Description		Material
Nut		304 stainless steel
Nipple Butt-Weld type		316L VAR/VIM+VAR
Nipple Face Seal type		316L/VAR
Nipple NPT type		316L
Outlet Plug With Ring & Chain	Toroid Piece	316L stainless steel
	Nut body, Screw	304
Outlet Cap		316L stainless steel
Gasket		Nickel 200 (35ft-lb)
		PCTFE (12ft-lb)
		Stainless Steel (30ft-1b)

Features

- 100% visual inspection in clean-room.
- Cleaned and packaged in a Class 100 clean-room environment.
- Leakage proof test at 1×10^{-9} atm. cc/sec.

Gas Connection Assignment Table

Gas	Formula	UHP CGA
Ammonia	NH ₃	720
Argon	Ar	718
Arsenic Pentafluoride	AsF ₅	642
Arsine	AsH ₃	632
Boron Trichloride	BCl ₃	634
Boron Trifluoride	BF ₃	642
Carbon Dioxide	CO ₂	716
Carbon Monoxide	CO	724
Chlorine	Cl ₂	728
Diborane	B ₂ H ₆	632
Dichlorosilane	SiH ₂ Cl ₂	636
Diethylzinc	Zn(C ₂ H ₅) ₂	726
Diethyltelluride	(C ₂ H ₅) ₂ Te	726
Dimethylzinc	Zn(CH ₃) ₂	726
Disilane	Si ₂ H ₆	632
Germane	GeH ₄	632
Halocarbon 11	CCl ₃ F	716
Halocarbon 115	ClCF ₂ CF ₃	716
Halocarbon 12	CCl ₂ F ₂	716
Halocarbon 13	ClCF ₃	716
Halocarbon 14	CF ₄	716
Halocarbon 23	CHF ₃	716
Halocarbon 116	F ₃ CCF ₃	716

Gas	Formula	UHP CGA
Helium	He	718
Hydrogen	H ₂	724
Hydrogen Bromide	HBr	634
Hydrogen Chloride	HCl	634
Hydrogen Fluoride	HF	638
Hydrogen Sulfide	H ₂ S	722
Krypton	Kr	718
Neon	Ne	718
Nitrogen	N ₂	718
Nitrogen Trifluoride	NF ₃	640
Nitrous Oxide	N ₂ O	712
Oxygen	O ₂	714
Perfluoropropane	CF ₂ (CF ₃) ₂	716
Phosphine	PH ₃	632
Phosphorus Pentafluoride	PF ₅	642
Silane	SiH ₄	632
Silicon Tetrachloride	SiCl ₄	636
Silicon Tetrafluoride	SiF ₄	642
Sulphur Hexafluoride	SF ₆	716
Trichlorosilane	SiHCl ₃	636
Triethylaluminum	(C ₂ H ₅) ₃ Al	726
Tungsten Hexafluoride	WF ₆	638
Xenon	Xe	718

Technical Specification

CGA Fittings Installation Instructions

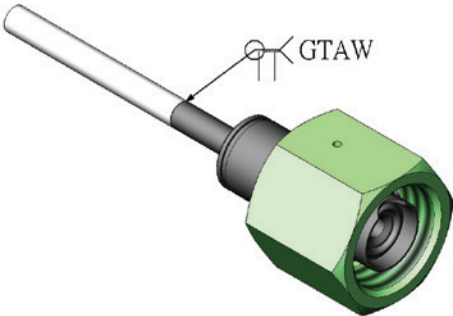

1. Assembly the nipple with the nut, then butt-weld with the tube.

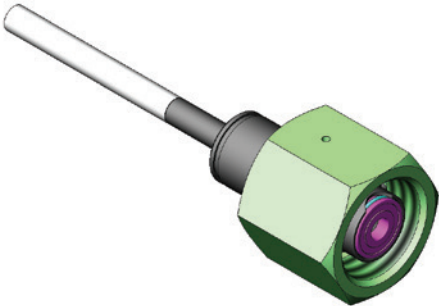

2. Install the diss gasket on the toroid of nipple.



3. Assembly the nut with the plug, then tighten slightly with fingers.



4. Please use the torque wrench to tighten the nut, and torque value of different gaskets can be set as below.

Material	Torque Value
Nickel 200	35 ft-lb
PCTFE	12 ft-lb
Stainless Steel	30 ft-lb

UHP CGA/DISS FITTINGS

Product Codes

Product Series Code	Description	CGA Number		Connection Type	Size
10	Nipple	632	712	BW (Butt-Weld) VC (Face Seal Male) NP (NPT Male)	2 (1/4")
		634	714		
		636	716		
		638	718		
		640	720		
		642	722		
			724		
			726		
			728		
20	Nut	CGA Number		Material	
		6 (632-642)		S (304 Stainless Steel)	
		7 (712-728)			
30	Gasket	Material			
		N (Nickel)			
		P (PCTFE)			
		L (316L Stainless Steel)			
50	Outlet Plug	CGA Number		Material	
		63 (632-642)		Toroid Piece : 316 Nut body, Screw Pin : 304	
		71 (712-718)	72 (720-728)		

Nipple (10)



Nipple Butt-Weld

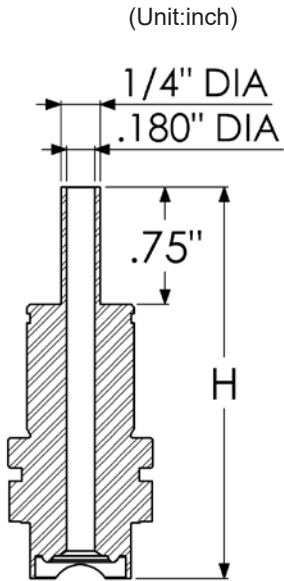

Nipple NPT Male

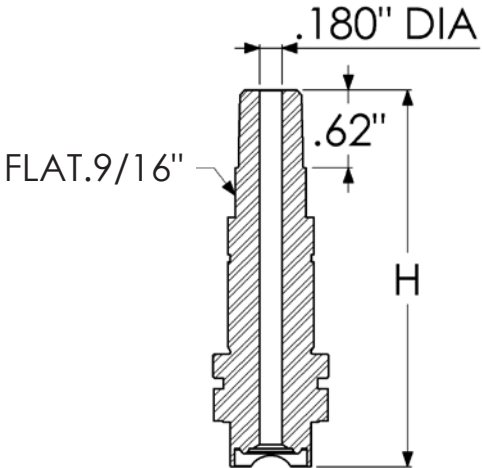

Nipple Face Seal Male

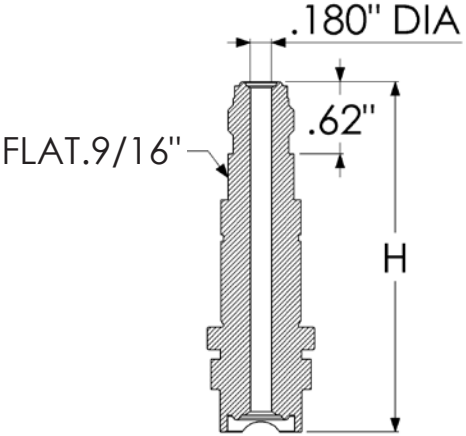

Nipple Product Table

CGA/DISS Number	End Connection	H Overall Length (inch)	Product Code
632	1/4" Butt-weld(BW)	2.50	10-632-BW-2
	1/4" Face Seal Male(VC)	3.00	10-632-VC-2
	1/4" NPT Male(NP)	3.00	10-632-NP-2
634	1/4" Butt-weld(BW)	2.50	10-634-BW-2
	1/4" Face Seal Male(VC)	3.00	10-634-VC-2
	1/4" NPT Male(NP)	3.00	10-634-NP-2
636	1/4" Butt-weld(BW)	2.50	10-636-BW-2
	1/4" Face Seal Male(VC)	3.00	10-636-VC-2
	1/4" NPT Male(NP)	3.00	10-636-NP-2
638	1/4" Butt-weld(BW)	2.50	10-638-BW-2
	1/4" Face Seal Male(VC)	3.00	10-638-VC-2
	1/4" NPT Male(NP)	3.00	10-638-NP-2
640	1/4" Butt-weld(BW)	2.50	10-640-BW-2
	1/4" Face Seal Male(VC)	3.00	10-640-VC-2
	1/4" NPT Male(NP)	3.00	10-640-NP-2
642	1/4" Butt-weld(BW)	2.50	10-642-BW-2
	1/4" Face Seal Male(VC)	3.00	10-642-VC-2
	1/4" NPT Male(NP)	3.00	10-642-NP-2
712	1/4" Butt-weld(BW)	2.50	10-712-BW-2
	1/4" Face Seal Male(VC)	3.00	10-712-VC-2
	1/4" NPT Male(NP)	3.00	10-712-NP-2
714	1/4" Butt-weld(BW)	2.50	10-714-BW-2
	1/4" Face Seal Male(VC)	3.00	10-714-VC-2
	1/4" NPT Male(NP)	3.00	10-714-NP-2

Nipple Product Table

CGA/DISS Number	End Connection	H Overall Length (inch)	Product Code
716	1/4" Butt-weld(BW)	2.50	10-716-BW-2
	1/4" Face Seal Male(VC)	3.00	10-716-VC-2
	1/4" NPT Male(NP)	3.00	10-716-NP-2
718	1/4" Butt-weld(BW)	2.50	10-718-BW-2
	1/4" Face Seal Male(VC)	3.00	10-718-VC-2
	1/4" NPT Male(NP)	3.00	10-718-NP-2
720	1/4" Butt-weld(BW)	2.50	10-720-BW-2
	1/4" Face Seal Male(VC)	3.00	10-720-VC-2
	1/4" NPT Male(NP)	3.00	10-720-NP-2
722	1/4" Butt-weld(BW)	2.50	10-722-BW-2
	1/4" Face Seal Male(VC)	3.00	10-722-VC-2
	1/4" NPT Male(NP)	3.00	10-722-NP-2
724	1/4" Butt-weld(BW)	2.50	10-724-BW-2
	1/4" Face Seal Male(VC)	3.00	10-724-VC-2
	1/4" NPT Male(NP)	3.00	10-724-NP-2
726	1/4" Butt-weld(BW)	2.50	10-726-BW-2
	1/4" Face Seal Male(VC)	3.00	10-726-VC-2
	1/4" NPT Male(NP)	3.00	10-726-NP-2
728	1/4" Butt-weld(BW)	2.50	10-728-BW-2
	1/4" Face Seal Male(VC)	3.00	10-728-VC-2
	1/4" NPT Male(NP)	3.00	10-728-NP-2

Nut(20)

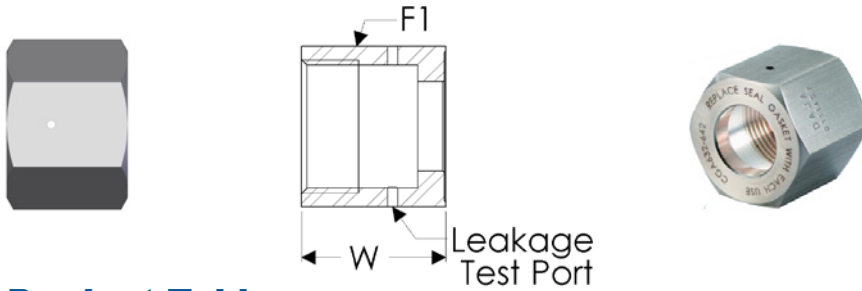

Nut Product Table

CGA/DISS Number	F1 Hex Flat	W	Product code
632 - 642	1-1/4"	1.13"	20-6-S
712 - 728	1-3/8"	1.13"	20-7-S

Gasket(30)



Nickel 200 / Stainless Steel 316L

PCTFE

Gasket Product Table

Material	A	H	E	Product Code
Nickel 200	.56"	.105"	.21"	30 N
PCTFE	.56"	.125"	.21"	30 P
Stainless Steel 316L	.56"	.105"	.21"	30 L

Outlet Plug(50)



Outlet Plug Product Table

CGA/DISS Number	End Connection	H	F	Product Code
632-642	Blank Plug	1.53"	1-1/8"	50-63-S
712-718	Blank Plug	1.53"	1-1/4"	50-71-S
720-728	Blank Plug	1.53"	1-1/4"	50-72-S

DAJA

High Purity Pipes & Pipe Fittings



Micro Butt-Welding Fittings



Iok-DJ® Compression Fittings

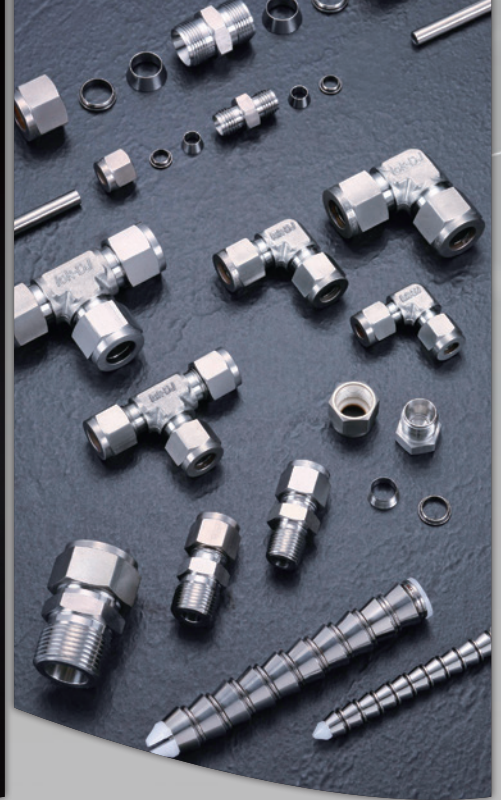

Metal Gasket Face Seal Fittings



HP Ball Valve



UHP CGA/DISS Fittings Series





Quality certification

1994: Certified to ISO 9002

1998: Certified to ISO 14001

2002: Certified to ISO 9001 (replacing ISO 9002)

2007: Certified to JIS MARK (JQA JIS B2312) (JQA JIS B2313)

2009: Certified to ISO 9001 : 2008

2013: Certified to JIS MARK (JQA JIS B2309)

2017: Certified to ISO 9001:2015

2020: Certified to NSF/ANSI 61-G

OUR PRODUCT & SERVICE

1. High Purity Pipe & Pipe Fitting.
2. High Purity Micro Butt-Welding Fittings.
3. High Purity Metal Gasket Face Seal Fittings.
4. UHP CGA/Diss Fittings Series.
5. Compression Fittings.
6. High Purity Ball Valves.
7. Manifold Pipe/Tube.
8. Contract Service: High Purity Welding components (in clean room).
9. Customized electro-polishing and UHP clean service.



Tachia Yung Ho Machine Industry Co.,Ltd.

UHP Components Business Division

Address: No.51, 39th Road, Taichung Industrial Park, Taichung City, Taiwan 407

Tel: 886-4-36000080 Fax: 886-4-36000081

<http://www.yhmco.com.tw>

大甲永和機械工業股份有限公司

潔淨級事業部

地址：40768 台中市台中工業區39路51號

電話：886-4-36000080

傳真：886-4-36000081